

DIMENSION (UNIT : mm)

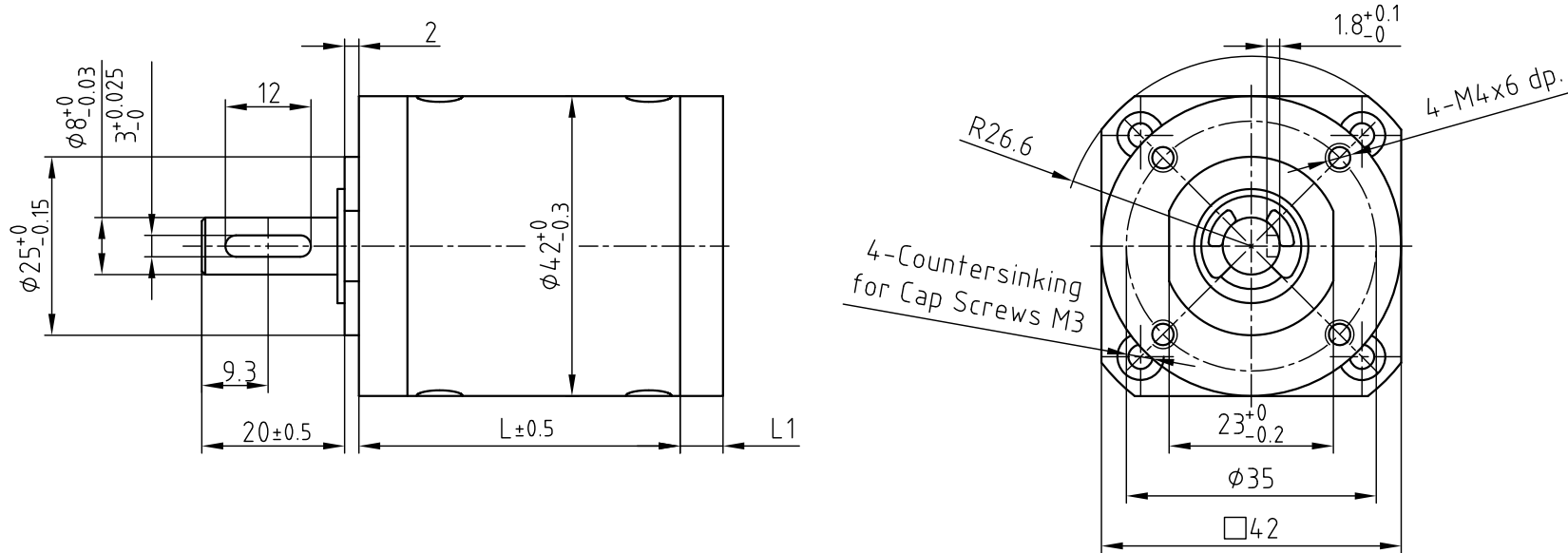

FLANGE SPECIFICATIONS

MOTOR	L1 (mm)
ST41.., ST42..	6.0
DB42	

GEARBOXES SPECIFICATIONS

RATIO	RATED TORQUE (Nm) max.	MAX. TORQUE (Nm) max.	EFFICIENCY (%)	RADIAL PLAY OF SHAFT (mm)	THUST PLAY OF SHAFT (mm)	L (mm)	WEIGHT (Kg)	SHAFT AXIAL LOAD (N)	RADIAL LOAD (10mm FROM FLANGE) (N)
1/14	1.0	3.0	70%	≤ 0.04	≤ 0.3	39.2	0.191	30	80
1/24	1.0	3.0	70%			39.2	0.191		
1/49	1.8	5.4	60%			45.9	0.231		

REV	DESCRIPTION	DATE	APVD		SCALE FREE	APVD	M 1:1	GPLL40+Zwischenflansch	
					X ±0.5	CHKD			DWG.NO
				1PL ±0.2	DRN	J.W.	14.11.2008		
				2PL ±0.1	SIGNATURE		DATE		
				ANGLE ±30'					