

Front view and mounting

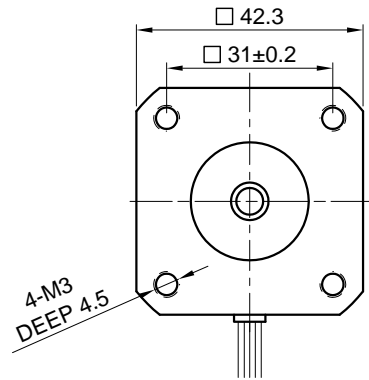

Side view

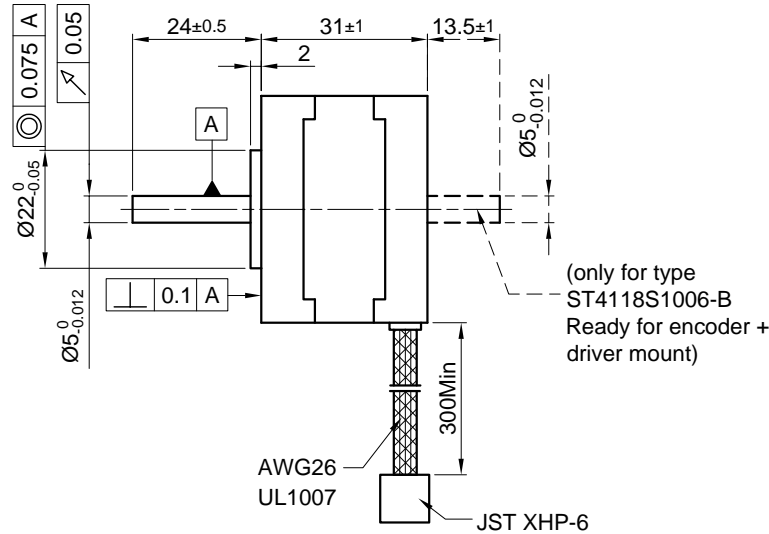

Rear view

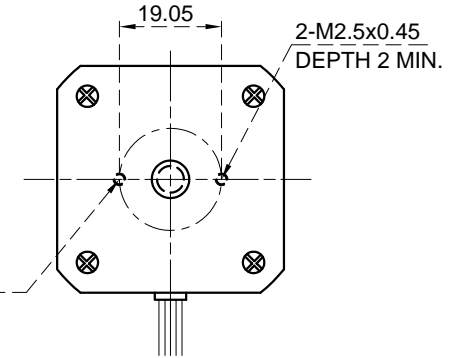

SPECIFICATION	UNIPOLAR OR BIPOLAR-1 WINDING	BIPOLAR SERIAL
VOLTAGE (VDC)	3.7	24.0
AMPS/PHASE	0.95	0.67
RESISTANCE/PHASE (Ohms)@25°C	3.9±15%	7.8±15%
INDUCTANCE/PHASE (mH) @1KHz	2.8±20%	11.2±20%
HOLDING TORQUE (Nm) [lb-in]	0.15 [1.416]	0.226 [2.0]
DETENT TORQUE (Nm) [lb-in]	5.9x10 <sup>-3</sup> [5.222x10 <sup>-2</sup> ]	
STEP ANGLE (°)	1.8	
STEP ACCURACY (NON-ACCUM)	±5%	
ROTOR INERTIA (Kg-m <sup>2</sup> ) [lb-in <sup>2</sup> ]	3.8x10 <sup>-6</sup> [1.3x10 <sup>-2</sup> ]	
WEIGHT (Kg) [lb]	0.2 [0.44]	
TEMPERATURE RISE: MAX.80°C (MOTOR STANDSTILL; FOR 2 PHASE ENERGIZED)		
AMBIENT TEMPERATURE -10°~ 50°C [14°F ~ 122°F]		
INSULATION RESISTANCE 100 MOhm (UNDER NORMAL TEMPERATURE AND HUMIDITY)		
INSULATION CLASS B 130° [266°F]		
DIELECTRIC STRENGTH 500VAC FOR 1 MIN. (BETWEEN THE MOTOR COILS AND THE MOTOR CASE)		
AMBIENT HUMIDITY MAX. 85% (NO CONDENSATION)		

PERMISSIBLE RADIAL+AXIAL FORCE

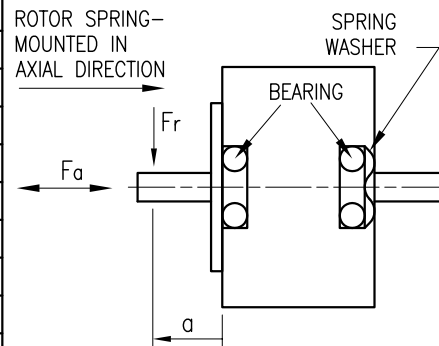

AXIAL-FORCE Fa (N)	Fa=7			
DISTANCE a (mm)	5	10	15	20
RADIAL-FORCE Fr (N)	58	36	26	20
	AXIAL	RADIAL		
SHAFT PLAY (mm)	0.08	0.02		
AT LOAD MAX: (N)	4.5	4.5		

TYPE OF CONNECTION (EXTERN)			MOTOR		
UNIPOLAR	BIPOLAR		CONNECTOR PIN NO.	LEADS	WINDING
	1WINDING	SERIAL			
A ---	A ---	A ---	1	BRN	A
COM ---	COM ---	---	5	BLK	COM
A\ ---	---	A\ ---	3	ORG	A\
B ---	B ---	B ---	2	RED	B
COM ---	COM ---	---	6	WHT	COM
B\ ---	---	B\ ---	4	YEL	B\

for >speed ←  
for <speed ←

FULL STEP 2 PHASE-Ex., WHEN FACING MOUNTING END (X)

STEP	A	B	A\	B\	CCW	CW
1	+	+	-	-	↓	↑
2	-	+	+	-	↓	↑
3	-	-	+	+	↓	↑
4	+	-	-	+	↓	↑

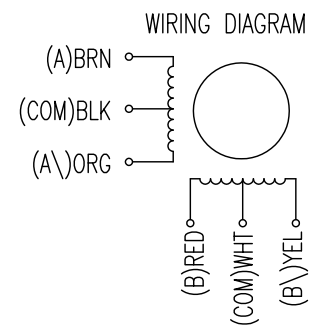

				NANOTEC:	SCALE FREE	APVD	<b>S.Hα.</b>	26.02.07	<b>STEPPING MOTOR</b>	
					X ±0.5	CHKD				
					1PL ±0.2	DRN	<b>J.W.</b>	29.11.06	DWG.NO	
REV	DESCRIPTION	DATE	APVD	ST4118S1006	2PL ±0.1	SIGNATURE		DATE		ST4118S1006
					ANGLE ±30'					